

Installation and operating manual

Solar differential controller

for absorber equipment

osfi Solar-11



osfi Solar-1



CE

Specifications:

| | |
|-----------------------------------|----------------------|
| Controller: | |
| Dimensions: | 140mm x 125mm x 65mm |
| Operational voltage: | 230V/50Hz |
| Control system power consumption: | ca. 2VA |
| Switching capacity: | max. 4A |
| Protection class: | IP 40 |
| Water temperature sensor: | |
| Dimensions: | ø13mm x 52mm |
| Cable length: | 5m |
| Operational voltage: | max.12V |
| Protection class: | IP 67 |
| Solar sensor: | |
| Dimensions: | 63mm x 20mm x 25mm |
| Cable length: | 20m |
| Operational voltage: | max.12V |
| Protection class: | IP 67 |

osfi Controls "Made in Germany"

Function:

This controller regulates the temperature of a swimming pool heated by solar energy. The water temperature can be set externally. A 2 or 3-way motor-driven valve with an operating voltage of 230 V (not included in delivery) is used for controlling the heating process. It is also possible to control a solar circulation pump (230 V). In the case of Solar-11, both the water temperature and the absorber temperature can be read off from the display.

The water and absorber temperatures are continuously monitored using two separate temperature sensors. If the absorber is warmer than the swimming pool water by an adjustable temperature difference, a motor-driven valve is activated so that the water is pumped through the absorber so that it can be warmed there by solar radiation.

If the absorber cools down so strongly due to the water flowing through it that appreciable warming of the water is no longer taking place, the motor-driven valve blocks the water feed until it can be warmed by solar energy once again. This alternating switching on and off of the absorber is repeated for as long as required until the swimming pool reaches the limit temperature which has been set. The absorber remains blocked off above this temperature. If this alternating process is to be prevented, the solar sensor must be installed on the roof next to the absorber so that it is continuously exposed to solar radiation. Installation of the sensor on the roof does, however, decrease the control accuracy of the control system, and we recommend professional installation on the absorber for this reason. If the differential temperature between the solar absorber and the swimming pool water is adjusted, the equipment can be optimally matched to local conditions (e.g. efficiency and heat capacity of the absorber, volume of the swimming pool, pump capacities etc). (See page 4).

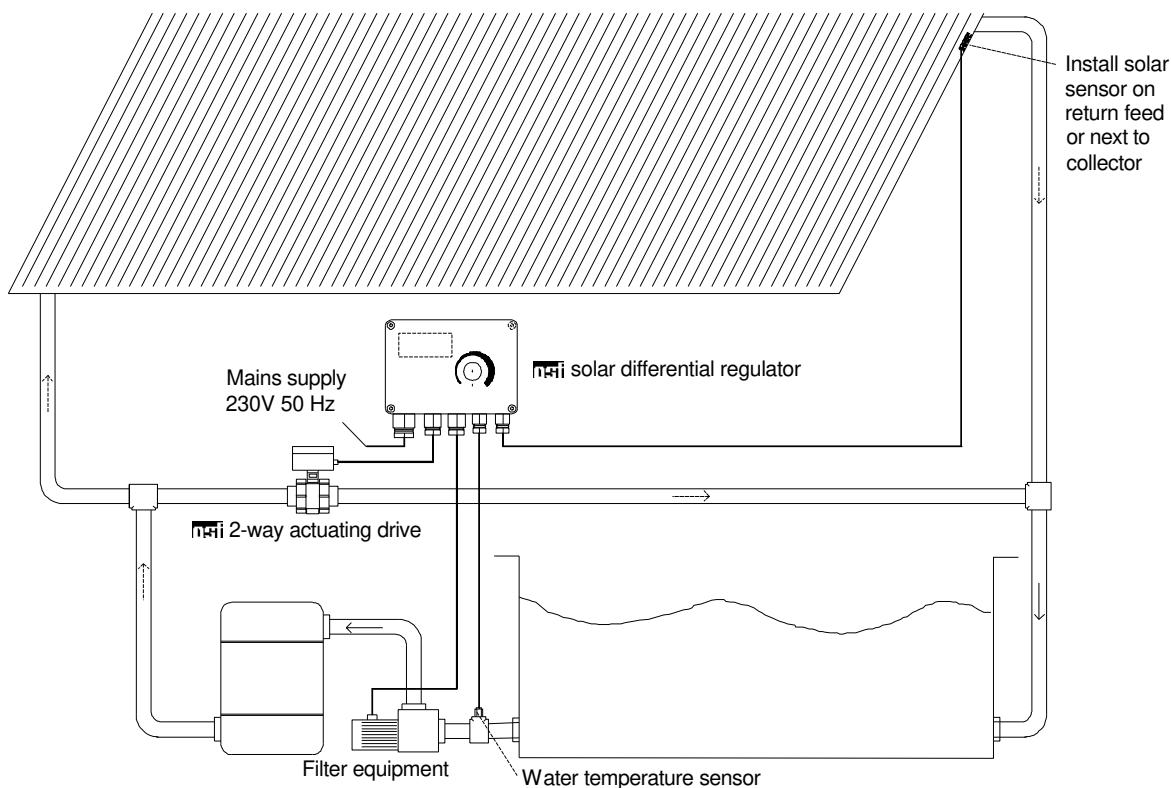

Installation

The controller must be mounted protected against moisture in accordance with its protection class. The device must be powered via a multi-pole main switch with a contact opening width of at least 3mm and a residual current circuit breaker with $I_{FN} \leq 30\text{mA}$. **The device must be isolated before opening the housing.**

The water temperature sensor is fitted to the filter pump suction or pressure line using the R $\frac{1}{2}$ " immersed sleeve available as an accessory, where it detects the current temperature of the swimming pool water.

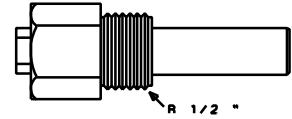

The black anodised solar sensor (aluminium) is attached to the absorber output side and measures the temperature of the water warmed by solar radiation in the absorber. When installing this sensor, please ensure that there is good heat contact with the absorber or with the returning, heated water. **On no account may it be in contact with cold swimming pool water on the input side.** The temperature at the temperature sensor installation site may not exceed 80 °C.

Electrical power supply:

Electrical power supply connections, in addition to alignment and service work, may only be carried out by approved electricians. The attached circuit diagrams and all applicable safety regulations must be observed.

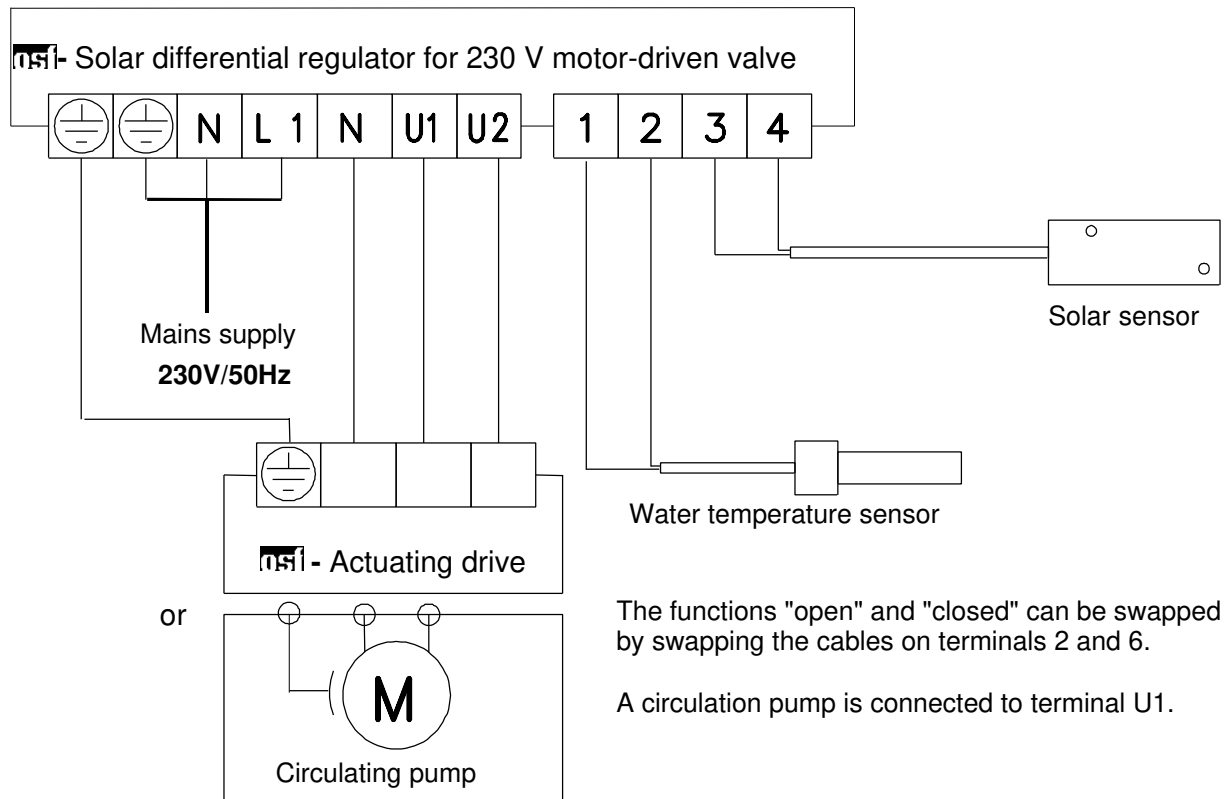

If actuating drives from other manufacturers are used, please observe the wiring diagram supplied with the actuating drive!

If water is to be pumped through the absorber, terminal U1 is under power and the indicator lamp will illuminate. Otherwise, terminal U2 is under power. The loading on the output terminals may not exceed 4A (especially important if the motor-valve and circulation pump are in parallel).

Only the original temperature sensors as supplied may be used. The sensor cables may not be routed together with mains cables. If required, it is possible to extend the sensor cables up to 25 m in length if screened cables are used (minimum 0.34 mm²).

The sensor system and the control unit are matched to one another and may not be replaced.

Sensor balance

After individual sensor systems have been replaced, balancing may be carried out again at the controller since the inevitable tolerances in the sensor electrical properties would otherwise lead to inadmissibly large measurement errors. This balancing may only be carried out when the controller is switched on and the housing has been opened. **Since some components in the controller carry life-threatening mains voltage (230 V!) this work may only be carried out by a qualified electrician!** An **TSI** service terminal is necessary to measure the signal voltages in the controller, and a suitable thermometer is also required for determining the relevant water and absorber temperatures.

Maintenance and service work may only be carried out by an authorised electrician.

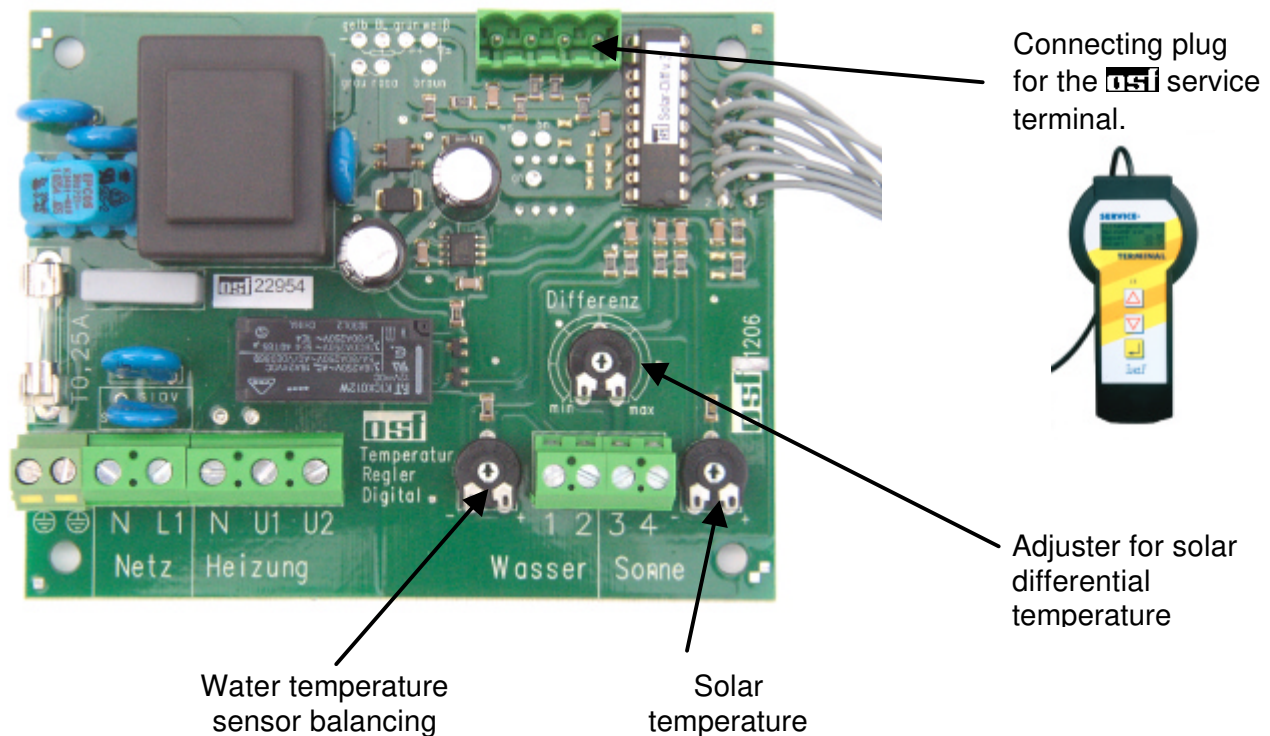

Service Terminal (customer service measuring device)





The service terminal plug may only be plugged in or pulled out when the main switch has been turned off.

The following display is visible in the service terminal:

| | | | |
|-------------------|---------------|---|---|
| Wasser: | 28,4°C | ← | Temperature at water temperature sensor |
| Sonne: | 34,9°C | ← | Temperature at solar temperature sensor |
| Sollwert: | 32,0°C | ← | Set target value (required temperature) |
| Differenz: | 5,2K | ← | Set differential temperature |

If the values displayed at the temperature sensor do not match the actual temperatures, an corresponding balancing process can be carried out at the appropriate "*sensor balancing*" adjusters.

The solar heating can be switched on manually using the  key on the service terminal, and off again using the  key.



The solar differential regulator must be switched off at the mains switch before removing the service terminal plug.



Service Terminal

Item No.: 301.000.0900

We hope you have a lot of enjoyment and relaxation in your swimming pool

Subject to alterations!

 December 10